



## INSTRUCTION AND MAINTENANCE HANDBOOK

**TRIKES TYPE**

**GTE 503 SE/S**

**GTE 582 SE/S**

**CLIPPER**

**I) Drawings**

**II) Technical specifications - Performances**

**III) Instructions for use**

**IV) Maintenance**

# I) Drawings

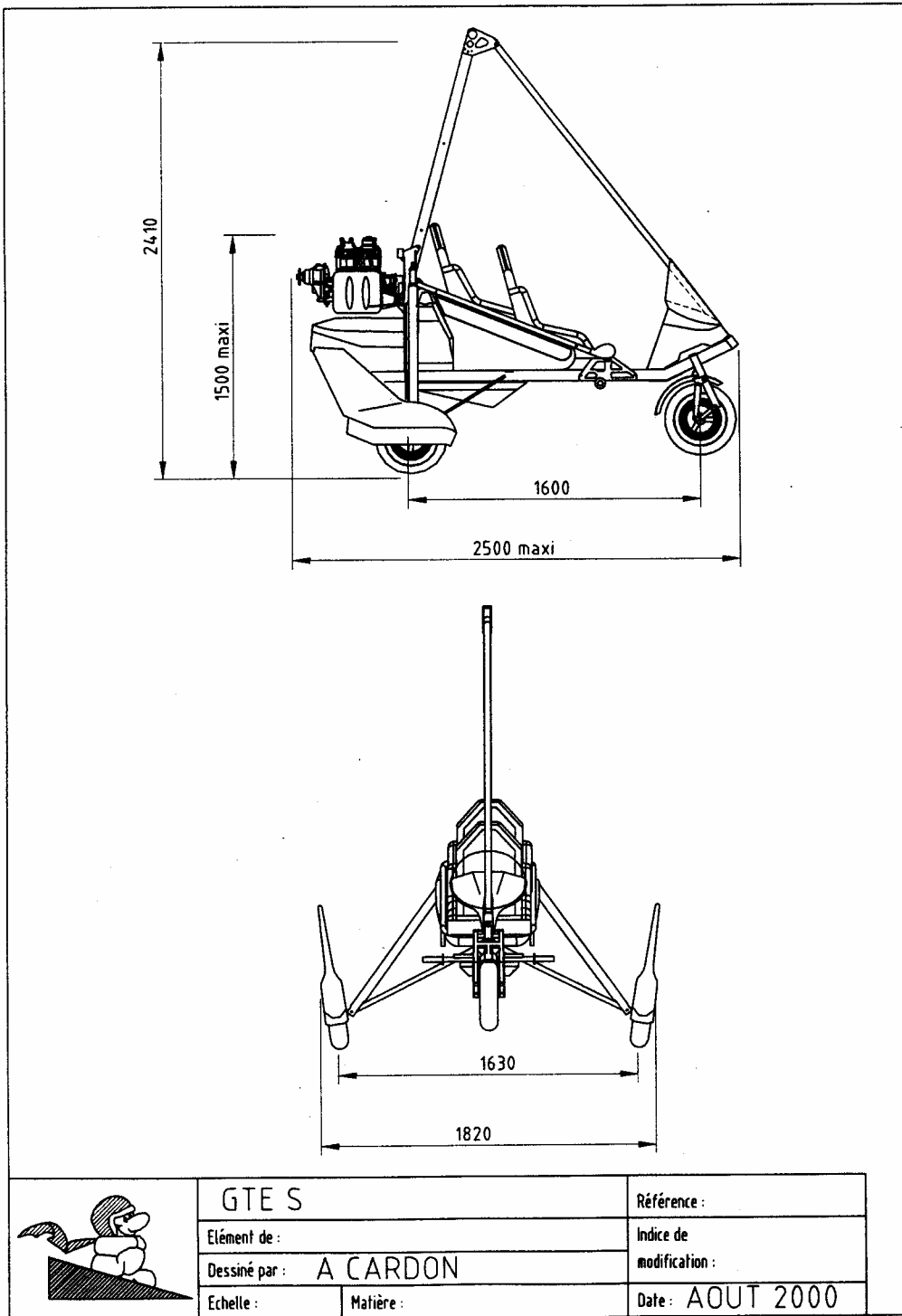

## II) Technical Specifications - Performances

	<b>GTE 503 SE(S)</b>	<b>GTE 582 SE(S)</b>	<b>CLIPPER 582 SE(S)</b>
Empty weight (Standard)	130 kg -287 lbs	139 kg - 306 lbs	150 kg -331 lbs
Maximum weight	398 kg - 877 lbs	398 kg - 877 lbs	398 kg - 877 lbs
Ultimate load factors at max weight	+6g -3 g	+ 6g -3g	+6g -3g
Limit load factors	+4g - 2g	+4 g -2g	+4g -2g
Fuel tank Capacity	15,85 US gal(60 l)	15,85 US gal (60 l)	15,85 US gal (60 l)
Engine	Rotax 503	Rotax 582	Rotax 582
Max. power	52 HP	64 HP	64 HP
Max. rpm	6800 rpm	6800 rpm	6800 rpm
Reduction Drive	Mechanical	Mechanical	Mechanical
Ratio	1:3.47 / (1:4)	1:3.47 / (1:4)	1:3.47 / (1:4)
Max. propeller rpm	2000 rpm (1700 rpm)	2000 rpm (1700 rpm)	2000 rpm (1700 rpm)
Measured noise level Lm at max. wt - max. rpm	76 dB (75 dB)	72 dB (71 dB)	72 dB (71 dB)
Noise level corrected Lr	76 dB (75 dB)	72 dB (71 dB)	72 dB (71 dB)
Height from ground H	60 m	75 m	75 m
Minimum height from ground For a noise inferior to 65 db at Maximum power	190 m (170 m)	160 (140 m)	160 (140 m)

From the values shown above the on-the-ground loudness perception value Lh for aircraft flying at height h at maximum weight and rpm may be calculated using the formula:

$$L_h = L_r - 22 \log \frac{h}{H}$$

### **III) Instruction for use**

#### **a) Adaptation of wings and trikes**

**The GTE and CLIPPER trikes can only be fitted to the FUN 450, MILD, XP, KISS and iXess wings manufactured by AIR CREATION.**

The propeller diameter only allows assembly of short keel wings. Therefore, it is not possible to fit the following AIR CREATION wings: PLUS, QUARTZ, SX and FUN manufactured before March 1997. If the wing to be fitted was not supplied with the trike when purchased (different make or second-hand), check all parameters (height, displacement of the control bar, propeller clearance with keel ends) and make sure that there is at least 10 cm clearance between the propeller and the wing structure, when all possible angles of attack are ground tested.

#### **b) Rigging/ Unrigging**

- Lift the wing, rest it on the nose and into the wind.
- Wheel the trike behind the wing, line it up with the keel, pull the upper beam down and take the front tube out.
- Raise the upper beam, push the hang point into the hang bracket, position the Ø10 hang bolt, install the butterfly nut and the locknut, tilt back the lever in order to tighten the plates and secure with split ring.
- Slip the back-up fastening cable through the belt loop at the king post, running it once around it. Slip it through the belt loop again and fasten it to the trike beam. The back-up fastening cable should be run under the tensioning cables. This operation secures the trike to the wing, also securing the wing cross-bar tensioning system.
- Place the propeller so that no blade stands in front of the keel axis.
- Raise the wing nose into a horizontal position.
- Attach the front strut between the aluminum flanges at the top of the upper beam using the bolt and the butterfly nut.
- Pick up the 'A' frame tubes, take hold of the control bar and lift the wing while preventing the trike from falling backwards. The front strut can be fitted into its locating position when the wing is lifted high enough. When rigging solo, rotate the instrument console, sit down on the trike beam facing the 'A' frame, take hold of the control bar, place it on your knees, raise the wing and fit the front strut as indicated.
- Install the upper beam safety bolt on the engine support using the butterfly nut, tilt the lever back in order to tighten the plates, slip the split ring in the hole of the bolt.
- Install the bolt connecting the front tube with the lower beam; screw the butterfly nut, secure with split ring....
- Install the foam seat using the Velcro tabs. The front part of the rear bucket seat must be rolled around the frame seat, in front of the seat supporting strap, and then fixed with Velcro under this middle strap. Slip the Velcro between the seat frame and the different wires.
- Set into place the windshield of the panel by using the ¼ turn bolts.
- To disassemble reverse the assembly operations. Tilt the back of seat / container forward to the single-seater position before lowering the wing.

### c) Preflight checks

- Check the wing as indicated in its operating manual.
- Check the trike-to-wing attachments and all back-up devices.
- Check the front strut attachments to the trike upper and lower beams.
- Check the safety bolt on the upper beam-to-engine support attachment.
- Check propeller, exhaust and exhaust spring fasteners, air filter and rubber shocks mounts condition.
- Check fuel filter, fuel primer bulb, fuel tank valve, and fuel hose condition.
- Check coolant level in the expansion tank, water hose integrity, ensure that the radiator grill is free of debris, and check the radiator mount for water-cooled engine.
- If you suspect any water to be in the fuel tank (condensation, fuel quality), get rid of it with the help of the emptying system located on the top of the tank, opposite to the cap. Use the fuel primer pump located in the pouch behind the pilot seat. Replace carefully the obstruction cap at the end of the emptying system afterwards.
- Make sure the sidebags, the back of seat container and the luggage container, if installed, are closed.

### d) Trike and engine operation

#### – Foot Throttle

The power of the engine increases when pushing the top of the right pedal forward and decreases once you release the pressure on it.

#### – Hand throttle

Pushing the throttle lever forward increases power and pulling it back reduces power.

#### – Ground steering

The steering bar operates the front wheel direction. Push on the right side with your heel: the aircraft will turn to the left, and vice versa.

#### – Brake

Push the left pedal forward to operate the brake upon the front wheel.

#### – Ignition switch

Down : ON                      Up : OFF

#### – Fuel cock

The fuel valve is open when the lever is set horizontally in comparison with the ground, in the direction of the fuel flowing. The fuel valve is closed when the lever is pointing vertically.

– **Starting (manual engine start)**

- Fill the tank with a mixture of premium petrol (GB), gas(oline) (U.S.) and (50:1 mixture ratio) 2% synthetic oil (Recommended oil - CASTROL TTS).
- Open the fuel valve. Use the primer bulb on the fuel hose to prime the engine.
- Use the choke when the engine is cold.
- Place the throttle lever and foot pedal in the "idle" position.

**Warning: The only safe way to state whether the engine is in the idle position is to listen for the typical sound of the throttle valve closing. Move the throttle lever back and forth to idle position to check. Do not start the engine until you have heard this sound: the control cable may need adjustment or may have jammed. Both are dangerous and a complete loss of control of the aircraft may result when starting.**

- Select the parking brake with the rack sets on the pedal.
- Set the ignition switch to "ON" with the interrupter located behind the hand throttle.
- **Make sure that no one is standing close to the propeller and say out loud: "Clear prop" then pull the starter rope.**
- The high reduction ratio of the 582 S engines and the inertia of the propeller require a firm, powerful pull on the starter cord. Starting may be facilitated by 2 or 3 injections with the primer mounted on the engine support.
- After the engine has come up to working temperature, make sure both ignitions work independently by reversing the contactor set in front of the switch breaker box (Central position = ignition 1 + ignition 2), under the hand throttle. After the test, set the switch back to the central position 1+2.

**WARNING: For liquid cooling engine fitted out with a radiator under the lower beam of the trike, avoid a long-continued ground-run of the engine to prevent overheating due to lack of airflow wind particularly if the outdoor temperature is high.**

– **Inboard settling**

**WARNING: an accident may occur while getting on board if the throttle lever is involuntarily moved forward. To eliminate this possibility, we recommend to get on board by the left handside of the trike and to be careful not to bump into the hand throttle on the right handside of the trike.**

- The positions of the front fork and the passenger foot-rest are adjustable for every one's comfort. Two holes situated on the lower beam of the trike allow for an adjustment of the fork and the pedals. For the passenger foot-rest, install the tube by positioning it above or under the lower beam. For dual control use, each modification in positioning the fork also involves changing the length of the dual control link tube operation in the appropriate holes set at the ends.
- For a single-seater use, the movable luggage bag can be placed instead of the passenger foam seat, held by straps and Velcro fastenings. This bag is also usable as a back seat for the pilot, with the incorporated cardboard and rib. The load of the luggage bag set at the passenger place is limited to 25 kg (55 lbs.). It can be folded against the upper beam to be used as a back of seat for the passenger during two-seater flight.
- Step on the non-skid part of the lower beam in front of the seat frame to embark on the rear seat; do not use the dual control footrest.
- 4.5 lbs of varied tools can be placed in the pocket situated under the seat. The side bags have a carrying capacity of 11 lbs each (i.e. 5 kg each, material and luggage).

– **Prior to take-off**

- Check the fuel level in the tank and the opening of the cock.
- Fasten and check seat belts engagement. **WARNING:** Safety belts should be placed **at hip level** and tightened correctly. The strap loops under the seats are positioned to ensure correct safety belt positioning. Never remove safety belts from the strap loops under the seats: Safety belts fastened at abdominal level may cause internal injury in the event of violent shock.
- When aircraft is equipped with shoulder's strap, pull the buckle to release the winding system and fix it on the locating lug provided for this purpose, on the belt's side.
- Check ignition switch by rapidly switching OFF and then ON with engine operating.
- Check that the switch selector is on the central position 1+2.
- **Check that the control bar travel moves freely in roll and pitch axis.**
- Release the parking brake by a short depression of the brake pedal.

– **Take-off**

Use progressively full throttle when carrying a passenger. Throttle back slightly after having climbed 300 ft (100 m) to reduce engine wear. When flying solo, 3/4 throttle will suffice for take-off and climbing. Use full power only under critical conditions (short take-off runs, obstacles, high-altitude flight). In that case **never reduce or cut the engine** below the 300 ft (100 m) altitude to avoid dynamic stalling. For safety reasons, use the throttle lever rather than the foot pedal at take-off on rough terrain. **Never take-off with less than 2.5 gallons petrol (10 l).**

The recommended speed for initial climb is indicated in the wing's manual.

– **Cruising**

Keep the aircraft level with the throttle between 1/4 and full, depending on given airspeed. Avoid repeated and sudden power climbs and idle dives to prevent sudden engine temperature changes, which could damage the engine by thermal shock. Fuel tank content is easy to check from pilot's and passenger's seats as the tank is translucent and has a side gauge. Landing shall be considered before tank content has reduced to 1.5 US gallons (5 litres). This allows approximately 30 minutes reserve of flight at low cruising speed.

– **Landing**

The landing approach is best executed using the foot throttle and both hands on the control bar. At maximum load, keep the throttle at 1/4 of full power when on final to facilitate flare-out. Throttle back once the wheels touch the ground.

The final approach for landing is explained in the user's manual of the wing.

– **Parking**

Place the aircraft across the wind and place the extremity of the half-wing in the wind on the ground. Stop the engine with the ignition switch. Block the parking brake with the rack on the right side of the throttle. Block the control bar on the front strut of the trike using a Velcro. Leave the trike, pilot first, and always on the left side.

## e) Emergency procedures

### – Power failure on take-off

Should the power unit fail after take-off while still “at low height”, maintain aircraft control and safety approach speed, and land the aircraft straight ahead without attempting to turn back to the landing field. If time allows, set ignition switch off and fuel cock off

### – Power failure at altitude

If the engine fails for any reason, prepare for and carry out the emergency landing procedures as follow:

- Maintain aircraft control.
- Immediately establish the best glide angle speed.
- Check for suitable landing sites. Choose a number of preliminary options if time permits.
- Turn ignition key off.
- Close the fuel cock.
- Check pilot and passenger seat-belts are tight and secure.
- Check wind direction, either by natural indications such as smoke rising or by judging drift of aircraft over the ground, wind on the water.
- Choose the most appropriate landing site.
- Set up an approach as accurate as possible into wind.
- Remember your aircraft cannot be heard. Check that no one is on the landing site.
- Finalize your approach, deciding upon the best landing free of any obstacles.
- Use a short landing technique with safety.
- Evacuate the aircraft as quickly as possible, inviting the second occupant to do the same.

### – Restarting the engine in flight

- Set ignition switch to ON.
- Use the choke in the event of a prolonged stop.
- Exert a quick pull with both hands on the starter rope.
- Adjust throttle level then turn the choke off.

**WARNING: restarting the engine in flight may be tricky. Make absolutely sure you have a good margin of height and stay close to a landing field.**

### – Engine fire

Should an engine fire occur during flight:

- Maintain aircraft control.
- Maintain your flying speed.
- Set fuel cock off.
- Set ignition switch off.
- Carry out the emergency landing procedures as above.



## f) Empty weight

The standard empty weight which is used to calculate the reference empty weight of the whole aircraft does not include the options stated hereafter. So, think of taking from the useful weight indicated on the third page of the user's manual of the wing the weight of each option.

## g) Options

### 1) Luggage container

The container integrates perfectly with the tank shape, allowing 33 lbs (15kg) of luggage at the same time increasing propeller efficiency. To open the container, use a coin and give the Nylon screws a quarter turn. **Ensure that the luggage door is closed before flying**, objects could fall from the container and strike the propeller, which could be very dangerous. The useful load of this aircraft is reduced by 6.5 lbs (3 kg) owing to the weight of this option.

### 2) Parachute

The trike can be equipped with a pyrotechnic rocket parachute BRS, under the engine.

The parachute will slow the descent of both aircraft and occupants if a major problem occurs (collision, flight envelope exceeded, faintness etc.). ***It is advised to use it only as last solution to save life or reduce personal damages.***

Before starting the engine, the safety cotter pin placed on the launching handle should be removed. Then it should be replaced after landing, before going outboard, to avoid unintentional firing.

On the trikes equipped with an electrical start, it is recommended to link the engine key with the safety cotter pin, so its removal while using the trike cannot be forgotten.

Before firing the parachute, it is advised, ***if altitude allows***, switching the engine off to do not spoil the main bridle with the rotating propeller.

If you cannot stop the engine, it will be stopped at the same time you pull the handle of the parachute, due to the switch integrated on the handle fitting.

The activating of the rocket motor is made by pulling the red handle located between the pilot's legs, on the seat frame. ***Warning: a strong pull on the handle is needed, at maximum available length.***

Always inspect bridle connection points and activation bridles before flying and must not be modified. When rigging the wing, bridles must be fixed with the link shackle.

***The recommendations concerning inspection, activation and unloading of the rocket, maintenance periods and overall care are stated in the user's manual provided with the parachute.***

The parachute does not change the flight behavior of the microlight but its weight reduces the useful load by 22 lbs (10 kg).

### 3) Dual control for instruction

This option allows for control of the ground steering and the engine power from the rear seat. For instructors, it allows full control from the rear seat of the aircraft. It reduces the useful load of the GTE trikes by 2.2 lbs (1 kg).

#### 4) The "CLIPPER" Integral fairing

When equipped with integral fairing, luggage container and streamlined struts, the GTE trike is named "CLIPPER". This model is very comfortable for long trips, the windshield giving a very efficient protection for the pilot due to the deflection of air flow while at high speed operations.

The glide ratio is increased by 0.5 point and the max. speed by 3 mph (5 km/hour or 2.7 Kts). Landing distance is increased by 15 ft (5 m) due to its higher performance. The maximum useful load is 570 lbs (258 kg). The side bags can carry 2x 11 lbs (2 x 5 kg) of material; luggage container allows 33 lbs (15 kg).

The procedure for rigging the wing changes with the Clipper trike. The windshield must be, at first, dismantled with a coin turning the Nylon screws a 1/4 turn. Once the wing is fixed on the upper beam, lift it from the front of the trike which should be held by someone else by the hub of the propeller or locked with a strap rolled around the front wheel to the ground. This will prevent the trike from moving backwards or falling over. Once the locking screws of the front tube and the safety screws of the upper beam are set on the engine mount, the windshield can be refitted.

#### 5) Electric starter

This option reduces by 23 lbs (10.5 kg) the useful load of the GTE trikes. The starter is coupled to the gearbox reduction and the battery is set under the second occupant's seat. The starting procedure described under paragraph II d) is different. A three positions key contactor is either housed in the panel instrument (Clipper) or in the instrument console (GTE). The first catch switches on the circuit supplied by the battery (green light on); the second catch releases the starter. The switch breaker, fitted up behind the hand throttle, sets the contact of the ignition coils- "ON" = DOWN and "OFF" = UP.

To start, carry out the engine and trike preparation (prime fuel, starter, parking brake) and check **that no one is standing close to the propeller**, set the ignition switch to ON (switch breaker pointing down), turn the key in the first catch (red light is working), then in the second catch till the engine starts. Do not hold the key in this position, release it in order to be in the first position and push choke down as soon as you obtain a steady running. To control the good functioning of the dual ignition system, use the 3 positions switch set beneath the hand throttle box.

To stop the engine, set the ignition switch to off, and then the battery switch to off. **Remove the key so that rotation of propeller does not occur accidentally.**

Starting may be facilitated, in case of difficulties by allowing the battery to rest 30 seconds before attempting another start; do not try until it weakens entirely. Remember: the manual starter remains fully efficient if the battery runs down.

#### 6) Towing system

The towing system reduces by 2.2 lbs (1 kg) the useful load of the GTE trikes.

It allows streamers, advertising signs and hang glider towing.

Pulling the lever, set in the left lower part of the frame seat, backward releases the towing cable.

#### 7) Floats

An option proposes an installation kit for a pair of floats. A specific manual describes the assembling. Only the FUN 450, MILD 16, KISS 450 and XP 17 wings fit for this particular use in respect to their low minimum speeds. We recommend to practice only on lakes with soft wind regarding the high position of the centre of gravity and problems of corroding in sea areas.

The option weight, 50 kg (110 lbs.), reduces as much the useful load of the GTE trikes and limits the possibilities of assembling other optional equipment in order to respect the authorized maximum weight.

## **h) Specific use / security instructions**

### **1) Towing**

- The towing line must include a fuse gauged at 80 daN maximum in order to allow an automatic releasing in case of over-tensioning.
- Release the towing line above a fully clear ground before landing.
- Test systematically the releasing device of the trike before taking-off.
- The ideal speed for towing streamers is 47 mph (75 km/h). In the case of a glider, the speed should be adapted to its performances. The emergency procedures stated in chapter III e) remain applicable; the towing must be launched above a fully clear field prior to landing. Characteristics, listed in the chart in chapter II c) of the concerned wing user's manual, lessen due to the drag of towing and flying level requires a superior engine power. Minimum speed and stall speed remain unchanged.

### **2) Load carriage, survey material, data transmission, photography, video ...**

- Install the loads to be carried on the passenger seat. The holding device has to support efforts up to 9 g forward, 3 g upward et 1,5 g laterally.
- Limit the dimensions of the loads carried to avoid any contact, stress marks or blocking with the wing structure and particularly with the inferior longitudinal cables.
- Mounting any kind of camera at the tip of the wing is possible up to a maximum weight of 2 kg if you install a counterweight at the extremity of the opposite wing. The inertia of the wing on its roll axis will increase.
- The emergency procedures stated in chapter III e) remain applicable.

### **3) Sky jumpers**

- The place is always the back seat, such as in normal tandem or "sidesaddle", body perpendicular to the trike axis.
- Cut the engine before the preparatory step of the jump. You may use the wheel leg gear as a step.
- A repetition on the ground is absolutely necessary before taking-off.
- The emergency procedures stated in chapter III e) remain applicable. If altitude allows, the sky jumper will seat back to "normal position" before landing.

### **4) Floats**

- Mounting of floats increase considerably the inertia of the trike in roll and yaw and reduces its performances due to the increase of the total drag.
- The "taxiage" changes from the ground use by several aspects :
  - The center of gravity is set higher and the leaning surface is not rigid, which involves a greater sensitiveness to the wind (risk of flipping over). "Pilot" the wings according to the indications of the flight manual, even more carefully than on the ground.
  - The lack of brake requires a good management of the speed and you can fully stop only once the engine is off.
  - The components used for the structure of the trike are not intended for a use on the sea owing to the risk of corrodng and electrolytic stress due to the saltiness of this environment
- The emergency procedures stated in chapter III e) remain applicable.

## IV) Maintenance

### a) Transport

Trikes should preferably be transported on light trailers. Transporting the trike on a roof rack or in a van requires disassembling the rear undercarriage.

### b) Storage

The trike unit should be thoroughly checked and cleaned prior to storage. After cleaning, wipe all components with a clean lightly oiled cloth, while avoiding joints and rubberized parts.

If the trike unit is to be stored for a long period (e.g.:2-3 months):

- Place a well oiled cloth in the open end of the exhaust (leave it in evidence).
- Cover the air inlet filter with several layers of protection to prevent condensation.
- Drain the fuel tank.

### c) Running in

Your trike's engine has been factory-tested but requires running-in.

The engine should be run in on the ground as stated in the ROTAX instruction manual. Liquid-cooled engines equipped with a radiator placed under the keel of the trike should be switched off when the water temperature reaches 185° F (85°C) to cool down. We recommend running in these engines in flight with no passengers, adhering as closely as possible to the ROTAX instructions. Except for take-off, avoid using full power for long periods during the first twenty-five hours. After this period change engine oil and filter and make a general check of the engine of first ten hours and tighten the bolts of the cylinder head.

### d) Pitch of the propeller

The pitch of the ARPLAST propeller can be adjusted according to the wing used and the air density. A maximum ground speed of 5400 rpm is recommended for all the wings, except for the iXess which needs a maximum of 5200 rpm in order to prevent over-revving at full speed. Use the special tool and the Arplast manual to modify the pitch.

### e) Long storage

It is recommended to dismantle the trike sail in case of a long storage for several months. Fold it properly, in respect with its manual, to loosen the tensions and to protect it from ultraviolet. For the trike, you only need to place a cover or a sheet upon it and to prepare the engine according to the Rotax user's manual. Reverse the operation to use it and make a single-seater local flight test before using the aircraft as usual.

### f) Maintenance

For the maintenance of your engine, consult the Rotax manual.

**NEVER FLY USING AN UNBALANCED PROPELLER** (due to a shock or any projection). Vibrations generated will damage the reduction gear and the trike frame. To check propeller balance: Remove the propeller and hang it, free to rotate (see your dealer), by the hub center. If unbalanced, it should be returned to the factory for repair.

**Frequently clean the radiator grill of the air inlet as well as the radiator cooling box (for liquid cooled engine), in order to avoid obstruction due to grass or debris.**

### **Every 10 hours of flight time :**

- Change spark plugs.
- Check trike, engine and propeller nuts.
- Check the exhaust system, the rubber mounts and the springs.
- Check air filter condition and attachments.
- Check oil level in the reduction gear box, topping up when necessary.
- Check fan belt tension for air-cooled engine.
- Check liquid coolant, water pipes condition, make sure air intake of radiator is well clear for water-cooled engines.
- Check fuel filter condition/ cleanliness, attachments and ensure there are no leaks on fuel hoses.
- Check propeller condition.

### **Every 50 hours of flight time :**

- Check the engine rubber mounts.
- Change the 2 front wheel shock absorbers.
- Change the manual starter cord.
- Check the beams where the engine is mounted and around the swivel joint for cracks or movement.
- Check seams on welded assemblies and mounting holes for movement (engine support, front forks, hooking frame point, beam swivel joint, radiator mount.).
- Check rear shock absorber air pressure by exerting a lateral traction on the upper beam. Insufficient pressure will cause the trike suspension units to subside under load or lean excessively during turning on the ground or in cross-winds. Fill to 40 Bar using a special hand-pump where required (or see your dealer).
- **Every 25 landings maximum**, check the length of the sliding tubes of the « shock absorber » set. The difference (sets at full extension) should not exceed 2mm. If not, you should arrange for an overhaul. Moreover the overhaul of the “shock absorber” set has to be made **every 250 take-off or every 3 years of use**.
- Check condition and running of throttle and brake cables.
- Clean the air filter.

### **Every 100 flight hours :**

- Change gear box oil.
- Change hoses, fuel filter and fuel primer bulb.
- Decarbonize engine cylinders.
- Change throttle and brake cables, all bolts involved in frequent mounting/demounting operations (hang point, front strut, etc.), engine and propeller mounting bolts.
- Check tires, rims, wheel bearings front fork and wheel axles.
- Check engine support, hang point, undercarriage struts and links, wheel shafts and seat seams.
- Check upper and lower mounting connections of front tube. **Remove the upper and lower Nylon bases and inspect the tube where it enters the hole for ovalization or cracks.**

**After any heavy landing :**

- Check the front fork, remove and inspect the fork pivot and wheel axis.
- Check the seat frame and lower beam for distortion. Check seat seams.
- Check the upper beam and the front strut, the swivel joint (movement, cracks), the engine support and the engine mounting rubber mounts.
- Check the rear wheel assembly, loosening of assembly devices and shock absorber pressure.
- The structure of the wing must be completely inspected in our premises or by an approved technical establishment after any heavy landing or even for slight damages.

**WARNING :**

**Changing all NYLSTOP nuts after loosening is mandatory. Always secure such nuts using particular LOCTITE glue.**

# **PERIODICAL OVERHAULS BOARD**

Serial number : .....

<b>Date</b>	<b>Hours flown</b>	<b>Company which has carried out the overhaul address and stamp</b>

# **PERIODICAL OVERHAULS BOARD**

Serial number : .....

<b>Date</b>	<b>Hours flown</b>	<b>Company which has carried out the overhaul address and stamp</b>



# Notes

# TRIKE - QUALITY FORM

Anxious to ensure the perfection of our products, we have set a sequence of controls covering all the steps of production. We are working continuously on their improvement and we are in need of your help.

Please return this reply form accurately filled if you find any mistake or problem concerning your trike, which could affect its quality or finish, even if it is a minor one.

**Your name, address and telephone number :**

---

---

**Type :** \_\_\_\_\_

**Delivery date :** \_\_\_\_\_

**Trike number :** \_\_\_\_\_

**Engine serial number :** \_\_\_\_\_

**Distributor :** \_\_\_\_\_

**Hours flown :** \_\_\_\_\_

**Problems noticed :** (explanations and / or drawing)

