



INSTRUCTION AND MAINTENANCE HANDBOOK

Wing Type
KISS 450

I) Drawings

II) Technical specifications - Performances

III) Instructions for use

IV) Maintenance

I) Drawings

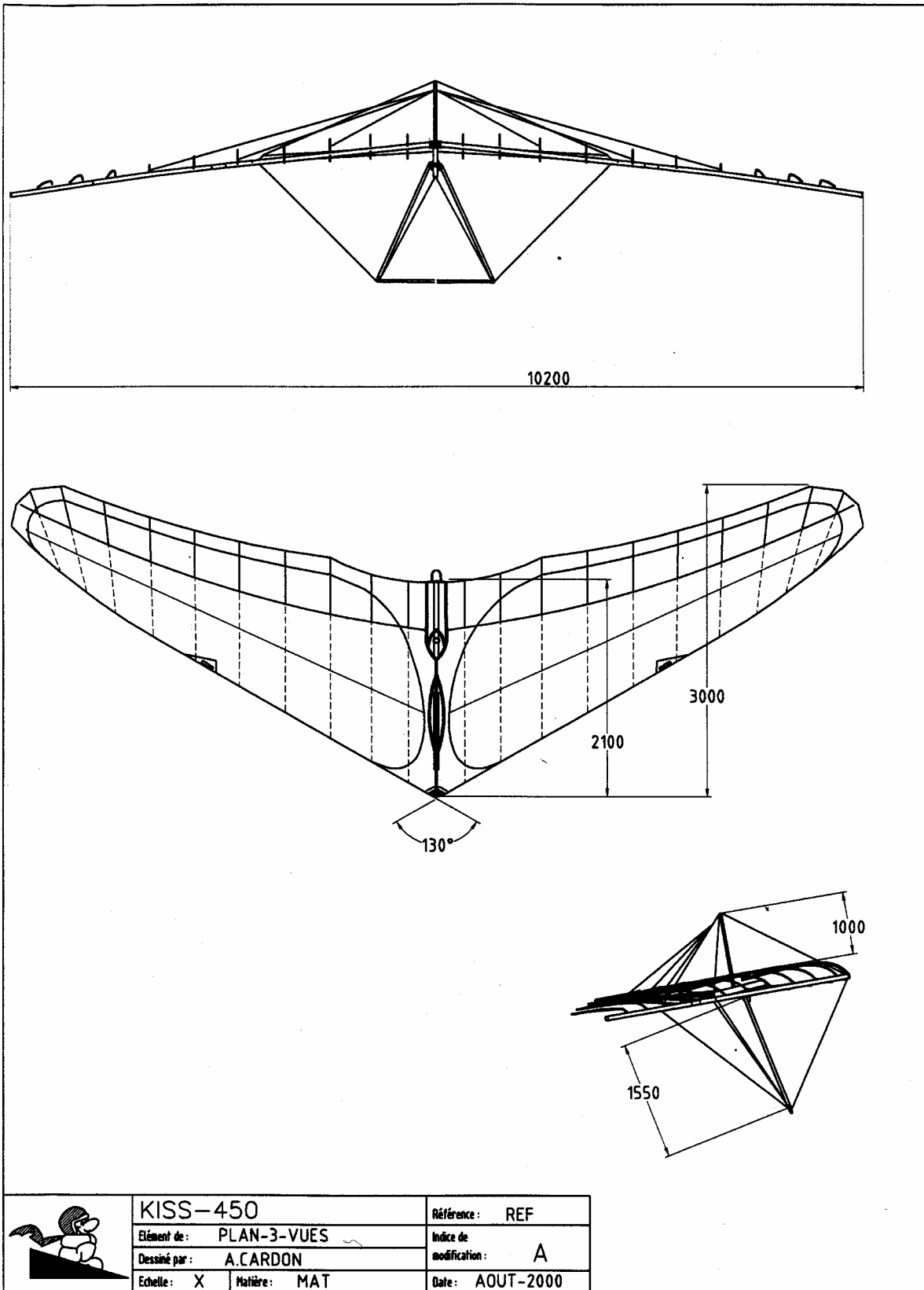

II) Technical Specifications - Performances

a) Technical specifications

Area	163 sq.ft. (15,10 sq.m.)
Airfoil type	Double surface 85%
Span	33 ft (10,20 m)
Nose angle	130°
Aspect ratio	7,5
Empty weight	106 lbs (48 kg)
Ultimate load factors	+ 6g - 3g
Maximum take-off weight	992 lbs (450 kg)
Limit load factors	+ 4g - 0g (- 2g under gust)

b) Maximum added load/ trikes adjustment

The following chart defines the useful load of our various trike models with the KISS wing.

	TWIN 503 (SL)	TWIN 582 SL (BUGGY)	GTE 503 SE/S	GTE 582 SE/S (CLIPPER)	GTE 912 SE/S (CLIPPER)	a.r.v TANARG 582	a.r.v TANARG 582
Empty weight (without options)	153 kg 337 lbs (161 kg) (355 lbs)	168 kg 370 lbs (180 kg) (397 lbs)	178 kg 392 lbs	187 kg 412 lbs (198 kg) (436 lbs)	221 kg 487 lbs (229 kg) (505 lbs)	215 kg 478 lbs	234 kg 516 lbs
Maximum empty weight*	278 kg 613 lbs	280 kg 617 lbs	278 kg 613 lbs	280 kg 617 lbs	282 kg 622 lbs	285 kg 633 lbs	286 kg 631 lbs
Useful load (without options)	293 kg 646 lbs (285 kg) (628 lbs)	278 kg 613 lbs (266 kg) (586 lbs)	268 kg 591 lbs	259 kg 571 lbs (248 kg) (547 lbs)	225 kg 496 lbs (217 kg) (478 lbs)	235 kg 522 lbs	216 kg 476 lbs
MTOW	446 kg 983 lbs	446 kg 983 lbs	446 kg 983 lbs	446 kg 983 lbs	446 kg 983 lbs	450 kg 992 lbs	450 kg 992 lbs

CAUTION: fitting of any equipment or any other change should never lead to exceeding the maximum empty weight value mentioned above, according to security standards and aircraft conformity.

Any, homebuilt or produced in series trike, weighing 402 kg (886,26 lbs) maximum, once loaded, may be fixed under the wing. In any case, some progressive tests will have to be done to check the adaptation wing / trike. The necessary engine power for safe two-seater flight should be at least 50 HP. Check during fitting whether the trike propeller stays clear of the lower rear longitudinal cables and the keel. **A minimum clearance of 10 cm (4 inches) should be respected when the hang point is set to the front position and the wing is at its most nose up and banked position.**

c) Performance at maximum take-off weight

TRIKE	TWIN 503	TWIN GTE 503 SL/SE/S	TWIN GTE 582 SL/SE/S (BUGGY CLIPPER)	GTE 912 SE/S (CLIPPER)	arv TANARG 582	arv TANARG 912
Stall speed	60 km/h	60 km/h	60 km/h	60 km/h	60 km/h	60 km/h
	37 mph	37 mph	37 mph	37 mph	37 mph	37 mph
Minimum speed	65 km/h	65 km/h	65 km/h	65 km/h	65 km/h	65 km/h
	40 mph	40 mph	40 mph	40 mph	40 mph	40 mph
Recommended climbing speed	80 km/h	80 km/h	80 km/h	80 km/h	80 km/h	80 km/h
	50 mph	50 mph	50 mph	50 mph	50 mph	50 mph
Take-off run	75 m	80 m	70 m	70 m	70 m	70 m
	246 ft	262 ft	230 ft	230 ft	230 ft	230 ft
50 ft clearing distance	160 m	165 m	150 m	140 m	150 m	140 m
	525 ft	541 ft	492 ft	459 ft	492 ft	459 ft
Climb rate	2 m/s	2 m/s	2.5 m/s	3.5 m/s	2.5 m/s	3.5 m/s
	394 ft/mn	394 ft/mn	492 ft/mn	689 ft/mn	492 ft/mn	689 ft/mn
Recommended approach speed	90 km/h	90 km/h	90 km/h	90 km/h	90 km/h	90 km/h
	56 mph	56 mph	56 mph	56 mph	56 mph	56 mph
Landing distance from 50 ft height	175 m	175 m	175 m	175 m	170 m	170 m
	574 ft	574 ft	(180 m) 574 ft	(180 m) 574 ft	558 ft	558 ft
			(591 ft)	(591 ft)		
Max L/D ratio	8	8	8 (8.5)	8 (8.5)	8.5	8.5
Max glide ratio speed	80 km/h	80 km/h	80 km/h	80 km/h	80 km/h	80 km/h
	50 mph	50 mph	50 mph	50 mph	50 mph	50 mph
Side wind limits	15 kts	15 kts	15 kts	15 kts	15 kts	15 kts
V.N.E. (velocity never exceed)	145 km/h	145 km/h	145 km/h	145 km/h	145 km/h	145 km/h
	90 mph	90 mph	90 mph	90 mph	90 mph	90 mph
V.max (never to be exceeded in very turbulent air)	95 km/h	95 km/h	95 km/h	95 km/h	95 km/h	95 km/h
	59 mph	59 mph	59 mph	59 mph	59 mph	59 mph
Roll rate at 120% V min. (45° / 45°)	4 s	4 s	4 s	4 s	4 s	4 s

III) Instructions for use

a) Assembling - Dismantling

- Open the wing bag, make sure that the A-frame is on top, and remove fastenings and packing.
- Assemble the A-frame with the push-pin. Cables must not pass through the inside.
- Turn the wing over, and carefully open the two half wings to their maximum extend.
- Fit the king post onto its locating lug, take care that the tensioning cables do not entangle and that they pass on each side of the king post.
- Carefully slide the upper sail battens in their respective pockets and secure them with the doubled ropes. Do not force the battens during the assembly.
- Place the two straight battens of the wing on the lug at the extremity of the leading edge. Carefully check the correct framing (sail tensioning screw in the axis of the keel) of the pivoting sleeves of the leading edge before tightening the cords.
- Slip the cross tubes swan catch tensioner through the opening at the king post location, pull to hook it on the rail screw tensioning at the keel tip. To simplify the operation carefully centralize the A-frame, push the A-frame to move the hanging device forward against its front stop on the keel and ensure that the heat shrink coverings of the lower lateral cables do not get stuck in the sail opening at the cross tube-to-leading edge connection.
- Pull down the swan catch tension lever and fix it in the rail with the push-pin.
- Raise the nose of the wing and lift it on it's A-frame.
- Fix the front lower longitudinal cables in the locating rail under the nose plate with the tension lever and **push the hanging device to the rear stop** on the keel.
- Pull down the swan catch tension lever and fix it in the rail with the push-pin.
- Lower the wing onto its nose. Slip bottom surface battens in their pockets and secure them with the rubber bands.
- Close the sail opening at the wing tip with the closing parts and their Velcro.
- When connecting the trike, slip the security fastening cable into the security strap at the king post level, make a turn backward around the king post, slip it again through the security strap, and then fix it on the upper beam of the trike. The security cable should pass under the tensioning cables. This operation secures connecting of the trike as well as fastening of the crossbar tensioning system.
- Fix the nose bonnet with the Velcro (essential point see "c" flight specifications).
- Dismantling is carried out in reverse order of the assembling operations. ***Before folding up the two half-wings***, place the leather cap on the tensioning device lever and pass it through the upper sail aperture at the front of the post bottom to avoid tearing any part of the sail or the structure while closing the leading edges.

N.B. : It is recommended to remove the nylon head of the king post from the supporting tube to have free movements to place the sail while avoiding sharp edges on the trim control wires when available on wings.

b) Preflight-check

A preflight check is essential before lifting the wing above the trike. To do so, position the wing horizontally once coupled with the trike.

- Check the camber of the two leading edges and correct positioning of the nose bonnet.
- Check the thimbles and nicopress of the front lower longitudinal cables and the correct fastening of the tensioning device and its pushpin.
- Slide your hand along the leading edges to check for possible defects.
- Check the crossbar/leading edges connection by unzipping the lower surface access. Check the right fastening of the lateral cables, the condition of these cables and their nicopress and the sail not being snagged on a metallic part.
- Check the fastening of the sails at the wing tips as well as the correct positioning of the two pivoting sleeves (the two screws should be positioned directly in line with keel), and the closing of wing tips.
- Check if the battens and their fastening rubber bands are securely positioned, check the condition of the reflex bridles and their fastening to the sails.
- Check if any of the upper cables is looped round the king post and if the reflex bridles are correctly positioned into the groove of the fixing pulley.
- Check the thimbles and nicopress of the rear lower cables at the keel tip.
- Check the tensioning of the crossbar cables, the correct positioning of the pushpin and its safety, as well as the condition, and fastening of the strap holding the sail at the rear of the keel.
- Slide your hand along all the lower cables to detect signs of wear.
- Check the connection of lower cables onto the A-frame , the condition of these cables and their nicopress, the pushpin of the control bar.
- Check the hanging point device, the condition and positioning of the tension cables (make sure they are not crossed) and check their holding strap at the front of the king post.
- Open both Velcro amidst the trailing edge of the lower surface to check the binding of both half crossbars and the fixing of the tensioning cables.
- Check the hang point device condition on the trike (possible twist, cracks), **and positioning against the stop on the rear bushing located on the keel** (an empty space between the hanging device and the front bushing is normal)
- Check the place and condition of the hanging device, its connecting bolt, its butterfly nut and its safety ring.
- Check the connecting of the hang point trike safety cable is correct. It must imperatively pass under the tensioning cables into the loop of the retaining strap, circle the king post and pass again inside the loop before fixing it onto the upper beam of the trike. This system ensures the fastening of the trike as well as tensioning of the crossbars in case of failure of one of the main components.

c) Flight specifications

WARNING:

The wing has not been designed for aerobatic flying.

Flight envelope's respect is imperative

- Pitch attitudes is limited to + or - 30°
- Roll banking limited to 60°
- No inverted flight
- V.N.E. (velocity never exceed): 90 mph (145 km/h)
- **Stalls authorized only in glide path with a progressive speed reduction and throttle to idle position.**
- Maximum take-off weight 450 kg (992 lbs.)

Over these limits, some stability problems, loss of control, structural failure or irreversible "tumbling" motions can occur.

Better handling will only be reached after about 10 flying hours and roll control will be more difficult during the first flights.

– **Control bar :**

Pushing the control bar forward causes the wing to pitch nose up ,which increases the angle of attack (the aircraft will climb) - primary effect, and a decrease in air speed- second effect.

Maneuvering the control bar laterally causes the trike to shift in the opposite direction of your movement, thus changing the center of gravity of the aircraft. It produces a roll movement in the direction of the trike displacement (control bar handed on the left, center of gravity moved on the right: .roll movement on the right)

– **Short take-off and landing techniques :**

The minimum take-off roll distance is reached by increasing R.P.M. to full power with brake, and raising the wing to its maximum from the very start of rolling. The control bar should be brought backwards immediately once the wheels are in the air to obtain a climbing speed ranging from 47 mph to 50 mph (75 km/h to 80 km/h) according to the load. A short landing needs a slow approach speed ranging from 47 mph to 50 mph (75 km/h to 80 km/h) and raise the nose a few meters before touching the ground, in order to touch the wheels at stalling speed. Brake and pull the control bar at its maximum in order to reach a better aerodynamic braking once the rear wheels have touched ground.

– **Behavior during stalling :**

The stalling point is reached more easily with a backward hang point position. Once the stall angle of attack reached, the control bar starts pushing back forcefully. Avoiding any resistance to this tendency for a short while allows the wing to recover a correct speed. In that case, the loss of altitude will be less than 33 ft (10 m). If the control bar stays pushed out despite the warning signs, the wing will stall and the loss of altitude may easily reach some 100 ft (30 m). An asymmetrical start on one wing is possible, particularly during the running in of the sail (first 50 flying hours).

To avoid tumbling risk, the stalling exercises must be imperatively carried out with engine at idle, with a slowly decreasing speed obtained by a progressive control bar pushing out.

Under certain conditions such as rain, the stalling speed of the wing can increase from 5 up to 10 km/h regarding the normal one. Be very careful during the approach and the landing, mostly in case of heavy load.

– **Banking :**

Banking of the wing has to go along with progressive pushing out of the control bar in order to ease the maneuver and to balance the banking. On the opposite, pull the control bar in, allows getting back faster in the horizontal line after banking. With a low cruise speed adjustment, it is necessary to increase the speed before the wing is put into banking to avoid stalling of the lower wing. An increase in engine power is also advised to maintain the flight level during the turn.

– **Behavior in strong wind :**

Once grounded and motionless

Park the aircraft perpendicularly to the direction of the wind, with its windward wing lowered. Fix the A-frame on the front tube of the trike with the Velcro used for packing the battens of the sail and put chocks under the three wheels. Take down the wing off the trike and put it flat on the ground windward, if the aircraft is not going to be used immediately.

– **Ground-runs :**

Keep the sail flat into a headwind. Push the control bar against the trike front strut with a tailwind. This will avoid flipping. Slightly lower the windward wing with a side wind. It may be difficult to hold the A-frame in its position. Never let the wind lift the wing up.

– **Take-off and landing :**

As ground run distances are considerably reduced by strong wind, try to face the wind. If it is impossible, perform the take-off and landing maneuvers with greater speed than you would normally do, in order to diminish the drift angle and counter the effects of the gradient. Keep to the axis of the runway with the front wheel control without considering efforts on the sail.

– **Load effect - dynamic stability :**

An increase of the carrying load will require more effort for pitch and roll, and create a small reduction of the cruising speed, (control bar released - trim) and an increase in stall speed. Continued or diverging pitch oscillations, about 10 seconds long, are possible if the control bar is released after a pitch motion pilotage or due to turbulence. To counter this typical phenomenon of flexible sails under load factors, it is better to go with the wing movements (one hand on the control bar is enough) in order to create the necessary damping to a progressive return to the cruising speed.

WARNING :

Do not fly without the nose bonnet and the removable fastener wings tips. Those streamlinings have considerable effect over pitch and roll stability of the wing. Their lack alters the internal pressure of the sail, which may result in great modifications of the airfoil shape.

d) Adjustments

- Hang point position

Move the hang point piece along the keel to adjust the hang point position. The uttermost back nylon locking ring is useful for the modification of the hanging point position (3 positions available). Do not ever move the front locking ring in order to allow the proper folding of the wing. **The hanging point piece must be replaced on the back locking ring**, an empty space being normal between the hanging point and the front ring. The hand-off cruising speed increase of about 3 mph (5 km/h) when moving the hang point 0,4 inches (1 cm) forward and vice versa. Each position may be used. It only changes the cruising speed, without any influence on stability and performances.

However, the hang point should never be placed to its most backward point on the keel if the total hanged load exceeds 772 lbs (350 kg). The cruising speed would be then too close to the stalling speed of the wing and make pilotage difficult. During the first flights, it is better to leave the hang point position in its original adjustment, which has been chosen to take the aircraft easily in hand. This standard position corresponds to the second position, beginning from the front. For the wings equipped with the optional trim, the most forward position is advised.

Warning : Any change in the hang point position means a variation of the A-frame tilt and therefore a different tension of the lower longitudinal cables. Various adjustment holes are designed in the cable fixation rail at the nose of the wing, allowing them to keep a correct tension whichever hang point position chosen.

- Trim option

This device allows, while in flight, the adjustment of the hand-free cruising speed by pulling the reflex bridles. Rotating the lever clockwise reduces cruising speed and inversely. The faster position, which gives the wing the natural cruising speed corresponding to the hang point position, is obtained once the wire loosens, at the end of the input. The rotation must be limited to prevent the cable to rewind in the opposite direction and a fold to occur.

The trim system pulls the wing nose up, and so it cannot accelerate the natural cruise speed beyond the one obtained naturally in accordance with the position of the trike hang point. It only allows slowing down. Therefore, it is advisable to set the hang point piece (APR) as forward as possible on the keel to get the most efficient range. Furthermore, before any take-off it is necessary to check the adjustment of the trim with the indicator set on the uprights. We do not recommend taking off with the trim set on the slow position. Indeed, the control of the wing is more difficult in case of an engine failure or in turbulent conditions as the pitch and roll control decrease at low speed. Set a central or trim position (neutral position). As well as for landing in heavy turbulences roll control will be uneasy with a slow trim set.

To keep the trim efficient in the long run, shift the sheath stop on uprights to tighten the wire again. Unscrew the holding bolt, then screw again once the adjustment made and pull down the excess sheath, in the clear part, between the high part of the A-Frame and the king post. The cable tensor being the upper stop for the control cable will have to be moved with an equivalent value.

The weight of the V-Max pack including the trim and the streamlinings of both the A-frame uprights and the king post, is 1,2 kg. Thus, the usable charge of the whole ultralight diminishes of this value once this option is set.

- **Position of the pivot sleeves at the leading edges tips**

The two bolts pivoting sleeves have been originally designed for the bolts fastening the sail to be in line with the keel. Their differential pivoting should only be used for rectifying a tendency to turn on one side. Once adjustment has been made, mark with a felt-tip pen the leading edge link with the sleeve or secure it with a pop rivet in order to find the correct position again at each assembling. If the wing pulls to the right, turn the left wing sleeve anticlockwise in order to increase the twist, and the right wing sleeve anticlockwise too, in order to decrease the twist. For a wing pulling to the left, turn the two sleeves in a clockwise direction. If the correction is insufficient for a perfect wing adjustment, use the tension of the sail as indicated in the next section.

- **Sail tension**

Modify the sail tension at the wing tip to rectify a dissymmetry observed in flight or to counterweight the aging effects upon the sail. To perform this adjustment, remove the protecting cap from the wing tips and rotate the bolt placed at its end with a 10 mm wrench. Put the cap back and readjust if necessary the tension of the small ropes of the inner and upper surface of the last wing tip batten, because of the modifications of the sail position on the leading edges tubes.

- In order to rectify the tendency to pull to one side, tighten the bolt on the leading edge of the "upward" half-wing and loosen the bolt of the "downward" half-sail, if it is not at its minimum tension adjustment already. Make two and a half turns at the utmost (2.5 mm tension) on each half-wing, and then test the aircraft. Repeat the operation until the wing is perfectly adjusted.
- To keep the original tension while sails get used, it is necessary to tighten the sail again symmetrically on the two leading edges. The first adjustment should take place after **50 hours of use**. A retensioning of 5 mm (5 turns) is necessary to keep the original characteristics of the wing. On one hand, tension increase on the leading edges means an increase in aerodynamic performance and in pitch stability of the wing. On the other hand, this operation alters the roll rate, to the benefit of the lateral stability.

- **Control of airfoil thickness**

The KISS wings comprise inner devices, which allow controlling airfoil shape and ensuring a balanced behavior when rolling and pitching over the whole speed range. In the center of the sail, these devices are adjustable. The factory performs these adjustments after the first flight of the wing. **The device is then definitely locked and no modification must be made afterwards, except by the workshop under specific conditions.**

IV) MAINTENANCE

Assembling the wing when folded in 4, 5 m :

Proceed as follows:

- Unfold the ends of the sail.
- Slide the rear leading edges through the opening at the wing tip and fit them in the front parts.
- Then, finish fitting the rear leading edges. Turn slightly and push in order to line up the half-hole and the horizontal bolt "connecting" the crossbars on the front part of the leading edge. Make sure that the plastic lugs at the rear of the tubes are face-to-face.
- Insert the sleeves of the wing tips holding the sail into the rear leading edges.
- Fix the sail onto the sleeves with the 4 FHC bolts and the nylstop nuts. For this, while holding the extremity of the leading edge, pull the sail on one of the two leading edges with a string that goes through the grommet, located at the extremity of the sail. Set the bolt corresponding to the internal grommet and the inner drilling of the wing tip sleeve. This process requires two persons. Make sure that the aluminum guide retainer, which adjusts the tensioning, faces the slot of the sleeve, at the tip of the leading edge. Set the other bolt after removing the string. Moderately tighten the nylstop nuts. Follow this procedure for the other leading edge. If you find it too difficult, first, remove the 2 self-tapping screws, which fix the sail on the leading edge to the nose wing. This way, the sail will move back easily. Replace these 2 screws once the wing is fully open and tensioned by pulling the sail or by turning it so that the grommets face the drillings. Watch out the position of the fabric around the nose plates and the nose batten on the stop pin at the front of the keel while opening the sail.
- Assemble the wing following the usual procedure. While opening the two leading edges, control the position of the central nose batten and check the wing is not jammed on the connecting screws.
- Rotate the wing tip sleeves, for the bolts fixing the to be in the keel axis in case of a previous adjustment requiring the sleeves to be dissymmetrical, line up with marks drawn on the tubes.
- Install the control bar on the revolving base fixed to the left trapeze strut with the 6mm CHC bolt, washers and nylstop nut. Close up the leather protection.
- Assemble the wing according to the normal procedure; check the sail fixations located at the end of the wing. Turn the rotating sleeves in order to line up the fixing bolts with the keel axis. Check the fixation of the control bar.

a) Transportation :

Bumpy and long drives might damage the wing unless it is properly loaded. Transport the wing and the trike by road requires that the wing, in particular, is properly braced, cannot shake about and is generally very carefully loaded and tied down, so that no hard points can damage tubes and sail. We suggest carrying the wing carefully on a ladder covered with foam rubber to avoid precarious overhanging.

b) Storage :

Keep it in a dry place, protected against U-V rays.

Clean it with fresh water after exposing it to sea air. Wash out any grass stain with water and regular soap.

Open the cover to allow the sail and the structure to dry after transport or use in the rain.

c) Overhauling

IMPORTANT

IN REGULAR CONDITIONS OF USE* A COMPLETE OVERHAUL OF THE WING IS ESSENTIAL EVERY 150 FLYING HOURS AND AFTER ANY HEAVY LANDING. THIS OVERHAUL INCLUDING COMPLETE SAIL AND STRUCTURE DISMANTLING, REPLACEMENT OF ALL SCREWS AND NUTS AND A SYSTEMATIC CONTROL, MUST BE CARRIED OUT IN OUR WORKSHOPS OR IN AN AUTHORIZED TECHNICAL STATION***. IT IS NECESSARY FOR SAFETY.**

* A peculiar use (mountain, tropics, sea environments and rough fields) requires a superior frequency, i.e. every year and every 100 hours.

** Or at least every two years if the wing flies less than 150 hours.

*** Whose operators follow a specific technical training in our workshops. An updated

* list is available on demand.

Ageing of the fabric and seams of the sails may cause an important reduction of the wing resistance. The degradation is principally caused through exposure to ultraviolet rays emitted by the sun and the moon. In order to slow down the process, the sail should be stored folded in its cover, or if it stays rigged, in closed premises. Always put it away in a sheltered place, shielded from the rays of the sun, even between flights. These measures help to lengthen sail life.

A strip of identical fabric as the one used for the top sail is stitched to it in the middle and over the keel pocket. The strip is made from two musters sewed together. During each periodical overhaul, part of the strip must be cut off, and submitted to a test of wear and tear in our premises. The results of the test determine when the replacement of the sail becomes essential for safety reasons.

Every 50 flying hours, check :

- Whether all screws are correctly tightened and that they have not worked loose as well as the reflex bridles links.
- Condition of the cables.
- The seams of the upper surface sail and the keel pocket in center of the wing.
- Possible tear of the sail and the rubber strap of the bottom and upper surfaces link.
- The maintaining strap of the tensioning cables forward the king post and the one which maintains the keel pocket.
- The correct condition of the ropes of the fixation battens. Reset or replace it again if necessary. The tension of the ropes maintaining the two last tip battens situated at the tip of the sail should be very firm indeed.
- Fastening bolts :
 - of the cables at the bottom of the A-frame
 - of the A-frame knuckle joints to the control bar
 - of the crossbar/leading edges link
 - of the tension device on the keel
 - of the hang point system
 - **Change them if there are any traces of wear or rust.**
- The swan nose catch and leading edges-to-keel connection plates to detect wear or cracks.

In the event of heavy landing, check imperatively :

- The straightness of the leading edges (imperative dismantling of the rear parts)
- The nose plate and its nuts
- The swan nose catch (wear - cracks)
- The straightness of the keel
- The lower cables
- The fastening of the sail at the wing tips
- The seams of the keel pocket on the sail
- The crossbars and their link with the leading edges
- The screws, the a-frame uprights
- The tensioning device at the rear of the keel
- The battens (airfoil symmetry)
- The fastening of the luff-lines on the sail

WARNING :

Every "nylstop" screw must be replaced after each *dismantling* and always tightened with a special glue of the "LOCTITE" type : 243 or 270.

All repair work should be carried out in our workshops or at an authorized technical station*

* Whose operators follow yearly a specific technical training in our workshops.

An updated list is available on demand.

PERIODICAL OVERHAULS BOARD

Serial number:

Date	Hours flown	Company which has carried out the overhaul Address and stamp

PERIODICAL OVERHAULS BOARD

Serial number:

Date	Hours flown	Company which has carried out the overhaul Address and stamp

Notes

WING – QUALITY FORM

Anxious to ensure the perfection of our products, we have set a sequence of controls covering all the steps of production. We are working continuously on their improvement and we are in need of your help.

Please return this reply form accurately filled if you find any mistake or problem concerning your trike, which could affect its quality or finish, even if it is a minor one.

Your name, address and telephone number :

Type : _____

Delivery date : _____

Wing serial number : _____

Colors of wing : _____

Distributor : _____

Hours flown : _____

Problems noticed : (explanations and / or drawing)

